

**Ke**  
**gi**  
**om**  
lifting



**380E4 SPIDER**  
MINI GRU CINGOLATA  
MINI CRAWLER CRANE  
MINI-RAUPENKRAN

DIMENSIONI / DIMENSIONS /  
GESAMTABMESSUNGEN



TABELLA PORTATA MASSIMA / LIFTING CAPACITY  
CHART / HEBEKAPAZITÄTSTABELLE



TABELLA PRESTAZIONI CON CESTELLO STABILIZZAZIONE MASSIMA /  
PERFORMANCE TABLE WITH BASKET MAXIMUM STABILIZATION /  
LEISTUNGSTABELLE KORB MIT MAXIMALER STABILISIERUNG

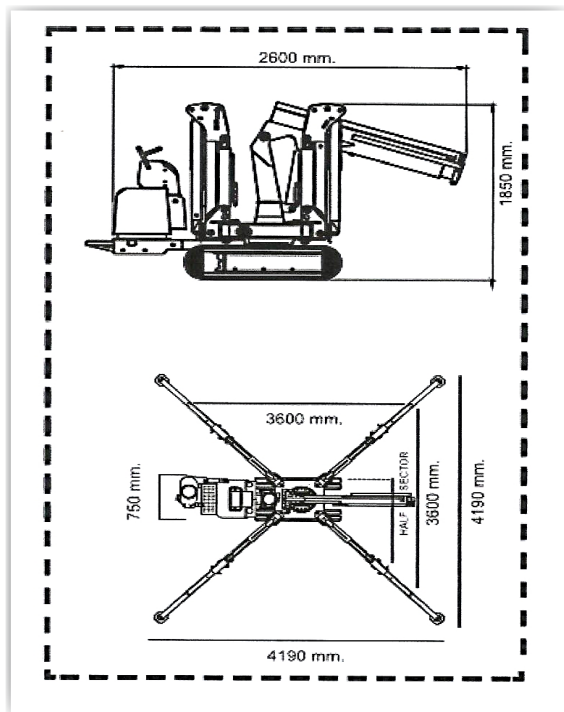

## SPECIFICHE TECNICHE / TECHNICAL SPECIFICATIONS / TECHNISCHE MERKMALE

### VERSIONE ELETTRICA / ELECTRIC VERSION / ELEKTRISCHE VERSION

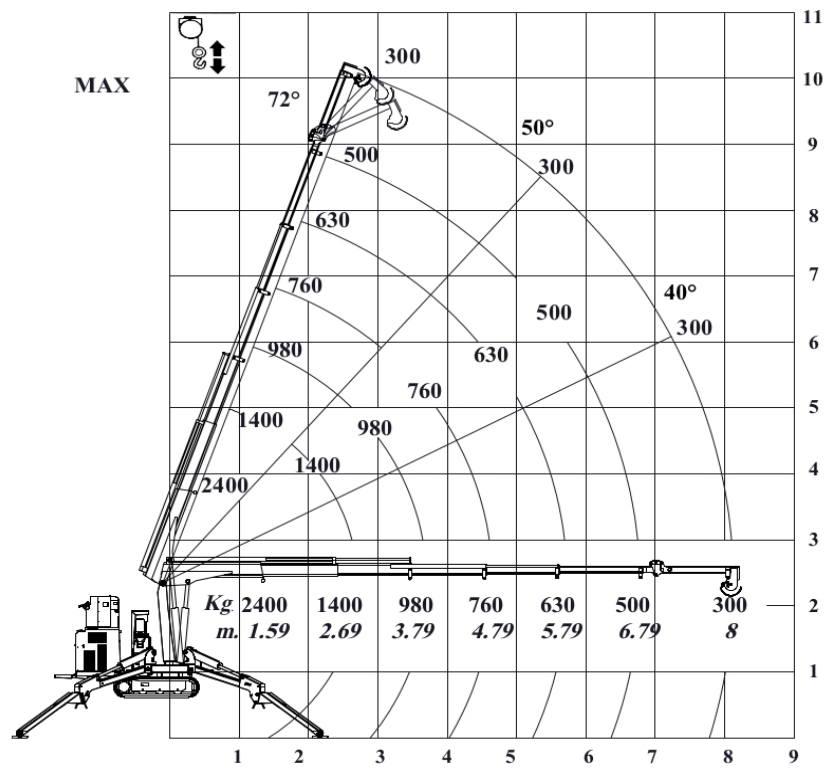
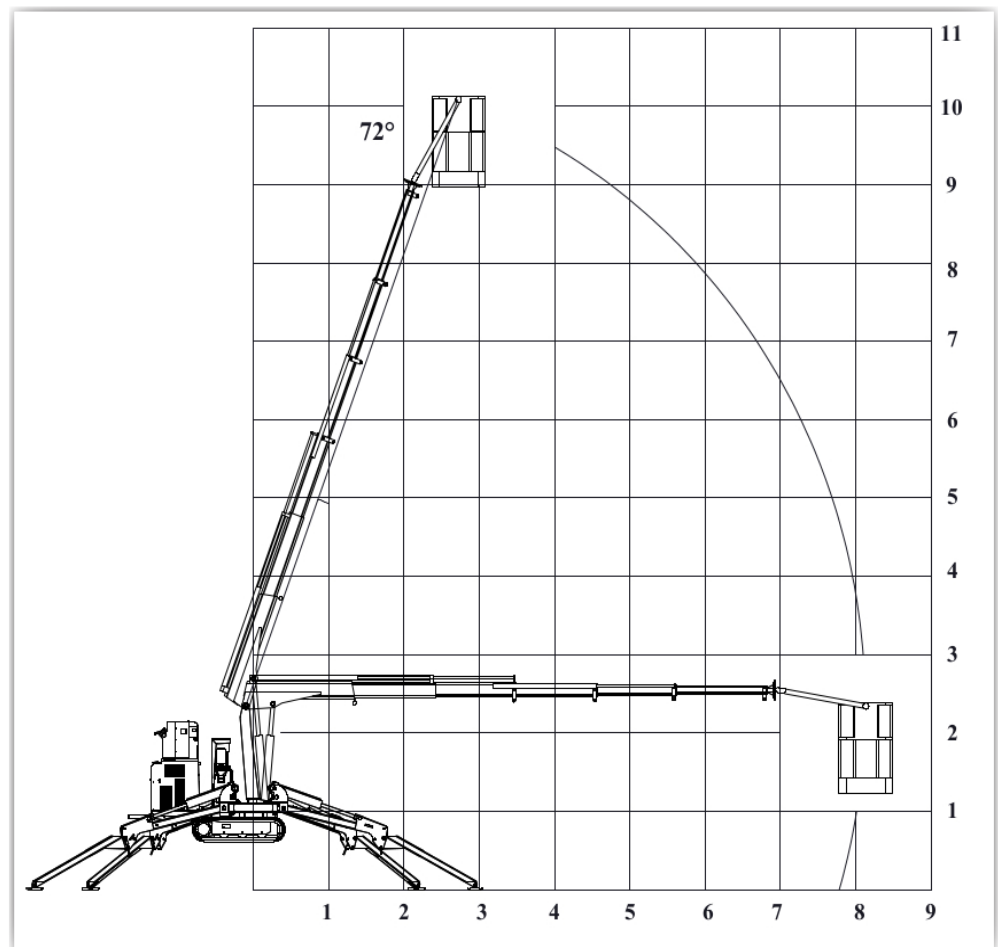
Motore / Motor	Electric motor 16KW - 48V
Batteria e caricabatteria Battery and battery charger Akku und Ladegerät	Lithium battery, 48V- 210Ah; Battery recharge 220V-50/60Hz with possibility of charging during the work

### VERSIONE MOTORE BENZINA

Motore / Engine / Motor	Honda GX 390 - 13 HP to 3600 rpm
Portata massima / Max Capacity / Max Kapazität	2400kg
Sbraccio massimo gru base + prolunga meccanica da 1 m Maximum reach of basic crane + 1m mechanical extension Maximale Reichweite des Basiskrans + 1 m mechanische Verlängerung	6,79m
Sbraccio massimo gru + meccanico da 1,50m Maximum crane outreach + 1,50 m mechanical jib Maximale Reichweite des Basiskrans + Hydraulikausleger von 1,50 m	8m
Sbraccio massimo gru + jib idraulico da 1,50m Maximum crane outreach + 1,50 m hydraulic jib Maximale Reichweite des Basiskrans + Hydraulikausleger von 1,50 m	8m
Altezza massima gru base + prolunga meccanica da 1m Maximum height of basic crane + 1m mechanical extension Maximale Höhe des Basiskrans + 1 m mechanische Verlängerung	8,50m
Altezza massima gru + jib meccanico da 1,50 Maximum height of crane + mechanical jib of 1,50 Maximale Höhe des Krans + mechanischer Ausleger von 1,50	10m
Altezza massima gru + jib idraulico da 1,50 Maximum crane height + 1,50 hydraulic jib Maximale Kranhöhe + 1,50 hydraulischer Ausleger	10m
Rotazione / Rotation / Umdrehung	360°
Fune	30m diam. 8
Dimensioni gru base	2600x750x1850mm
Peso gru base	1400kg
Peso Jib meccanico 1,50 m	35kg



DOTAZIONI STANDARD

STANDARD EQUIPMENT

STANDARD AUSRÜSTUNG

- |   |  |   |
|---|--|---|
| <ul style="list-style-type: none"> <li>• Gru con N° 4 sfili idraulici e N° 1 sfilo meccanico, colore rosso</li> <li>• Torretta gru a sezione chiusa con massima rigidità torsionale</li> <li>• Rotazione continua gru 360°</li> <li>• N° 4 Stabilizzatori idraulicamente estendibili con valvole di protezione, multi posizione</li> <li>• Telaio struttura monolitica con materiale ad alta resistenza</li> <li>• Cingoli in gomma intercambiabili, larghezza carro mm. 750</li> <li>• Avanzamento cingoli 2 velocità km/h 2,6 - 4,0</li> <li>• Limitatore di momento elettronico</li> <li>• Serbatoio carburante 6,5 l;</li> <li>• Serbatoio idraulico 30 l</li> <li>• Gancio girevole</li> </ul> | <ul style="list-style-type: none"> <li>• Crane with N° 4 hydraulic extensions and N° 1 mechanical extension, red color</li> <li>• Closed section turret with maximum torsional rigidity</li> <li>• Continuous rotation 360°</li> <li>• N° 4 multi-position hydraulically extendable outriggers with protection valves, grey color</li> <li>• Crane frame monolithic structure with high resistance material</li> <li>• Interchangeable rubber tracks, udercarriage width mm. 750</li> <li>• Two speeds crawler tracks km/h 2,6 - 4,0</li> <li>• Electronic limiting device</li> <li>• Fuel tank 6.5 l</li> <li>• Hydraulic tank 30 l</li> <li>• Swivel hook</li> </ul> | <ul style="list-style-type: none"> <li>• Kran mit N° 4 hydraulischen Auszügen und N° 1 mechanischen Ausschub, rote Farbe</li> <li>• Geschlossen Kranturm mit maximaler Torsionssteifigkeit</li> <li>• Endlos Umdrehung 360°</li> <li>• Nr. 4 hydraulische Multipositionsstabilisatoren mit Schutzventilen, graue Farbe</li> <li>• Monolithische Struktur des Kranrahmens mit hochbeständigem Material</li> <li>• Auswechselbare Gummiketten, Unterwagenbreite mm. 750</li> <li>• Zweistufige Geschwindigkeit km/h 2,6 - 4,0</li> <li>• Elektronische Lasthaltventil</li> <li>• Kraftstofftank 6,5 l</li> <li>• Hydrauliktank 30 l</li> <li>• Drehbarer Haken</li> </ul> |
|---|--|---|

## PRINCIPALI PUNTI DI FORZA

Facile da guidare può essere stabilizzata e lavorare su terreni ripidi e irregolari  
 Easy to drive it can be stabilized and work on steep and uneven terrain  
 Es ist leicht zu fahren und kann in steilem und unebenem Gelände stabilisieren und arbeiten

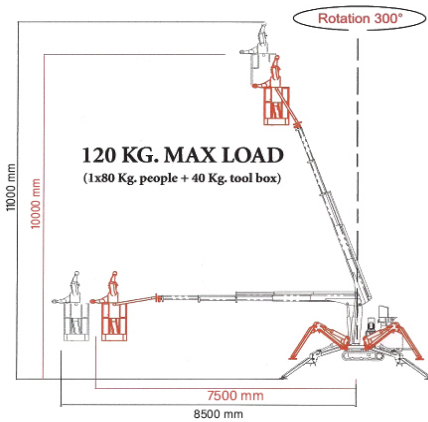

Le gru possono essere dotate di diversi tipi di cestelli CE  
 Cranes can be equipped with different types of operators baskets  
 Krane können mit verschiedenen Arten von Bedienkörben ausgestattet werden

## STRONG POINTS

Gli stabilizzatori regolabili riducono l'ingombro di lavoro della gru, rendendola ideale per spazi estremamente ristretti

The adjustable outriggers reduce the working space of this mini crane, making it ideal for work in extremely narrow spaces

Die verstellbaren Stabilisatoren verkleinern den Arbeitsraum dieses Kranes und eignen sich daher ideal für Arbeiten auf engstem Raum

Controlla la velocità di lavoro con precisione millimetrica  
 Control of the working speed with millimeter precision

Kontrolle die Arbeitsgeschwindigkeit mit millimetergenauer Präzision

## HAUPTSTÄRKEN

Veloce da caricare e trasportare la Gru può salire e scendere dal veicolo di trasporto con gli stabilizzatori  
 Fast to load and transport Schnell zu verladen und zu transportieren  
 Der Kran kann mit Stabilisatoren auf das Transportfahrzeug auf- und absteigen

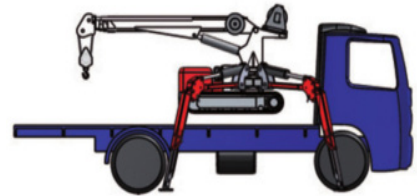

Cucita su misura con libera scelta tra tanti accessori sia di serie che appositamente pensati per soddisfare necessità del cliente finale  
 Tailor-made with free choice between many accessories both standard and specifically designed to satisfy the needs of the end customer  
 Maßgeschneidert mit freier Auswahl zwischen zahlreichen Standardzubehörteilen und speziell auf die Bedürfnisse des Endkunden zugeschnittenen Zubehörs



## OPTIONAL

	Argano ad alta velocità CE tiro diretto 990kg, 30m fune antigiro diam mm 8, fine corsa per il gancio.	Winch with 30 meters antirev. rope diam. 8mm single fall 990kg, End run for the hook	Hydraulische Seilwinde: 990 daN Direktzug, 30m Seillänge 8 mm Seildurchmesser, Seilkausche
	Fly-jib meccanico di 1,50m	Fly-jib mechanical 1,50m	1,50 m langer mechanischer Fly-Jib
	Gruppo elettropompa: Motore elettrico 230V o 400V, Pompa idraulica, Quadro elettrico;	Electro-pump set with traction wagon: Electric motor 230 or 400V, Hydraulic pump, Electric table	Elektropumpenset: Elektromotor 230 oder 400 Volt, Hydraulikpumpe
	Radiocomando proporzionale con 4 o 6 funzioni	Proportional Radio-command with 4 or 6 functions	Funkfernsteuerung: mit 4 oder 6 Funktionen
	Allargamento idraulico cingoli 750/1050 mm	Extensions Tracks 750 – 1050 mm	Schienenverlängerung 750 – 1050 mm
	Cestello auto bilanciato in alluminio – portata n 1 persona max 120kg	Basket in aluminum Dimensions ability: n 1 person max 120kg	Aluminiumkorb Abmessungen Fähigkeiten: n 1 Person max 120 kg
	Sollevatore a ventosa, vari modelli da 400 a 1200kg	Vacuum lifter capacity from 400 to 1200 kg	Vakuumheberkapazität von 400 bis 1200 kg
	Cingoli bianchi antitraccia	White non marking tracks	Non Marking Gummiketten
	Trattamento marino	Marine treatment	Meeresbehandlung